

PEX-AL-PEX Application

By Matt Brown

Abstract

APC uses Cross-linked Polyethylene piping as a reliable choice for distribution of water and glycol based cooling fluids through the InfraStruXure® Cooling Distribution Unit (CDU). Its construction allows flexible installation techniques that minimize joint use and prevent vibration transmission, while providing good strength and durability for system pressures under 1.03 MPa (150 psig). This paper will explain how Polyethylene pipe is made, its construction, uses, safety ratings, and design constraints associated with the material.

Introduction

PEX types, Materials and Construction

APC uses cross-linked polyethylene, PEX-AL-PEX piping to distribute chilled water from the InfraStruXure® Cooling Distribution Unit (CDU). What makes cross-linked polyethylene piping different from traditional polyethylene pipe are the cross link bonds added to its polymer structure. **Figure 1** shows a simple polyethylene molecule that is used to make high and low density polyethylene.

Figure 1 – Polyethylene molecular structure

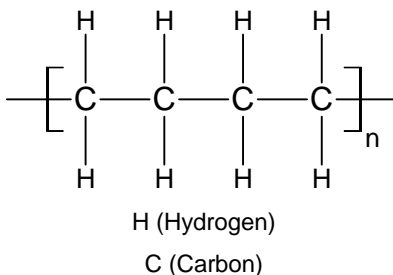
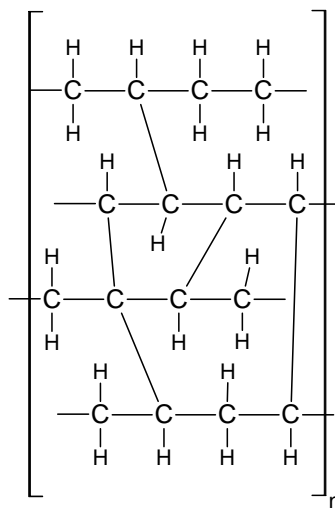

Figure 2 shows the cross-linking of the polyethylene molecules. Cross-linking creates covalent bonds between the molecules in many directions and gives the thermoplastic a more elastomeric structure. The jumbled strings of cross-linked molecules give the PEX better thermal stability at higher temperatures and pressures than traditional polyethylene pipe.

An added benefit of the cross linking process is better resistance to environmental stress cracking and crack propagation, which is defined as the crazing and cracking that may occur when a plastic under a tensile stress is exposed to aggressive chemicals. Cross linking levels in PEX piping are a minimum of 65% and can range up to 89% (ASTM Standard F 876-93).

PEX molecules do not contain fluorine or chlorine atoms. This means that PEX does not produce hydrofluoric or hydrochloric acids or gases if burned. When PEX burns it will produce water and carbon dioxide. As with all Carbon based fuel materials, there is some chance for carbon monoxide to be formed if the product does not burn cleanly.

Figure 2 – Example of cross-linked polyethylene molecular structure



PEX begins by taking high density polyethylene resin and modifying it either during a pre or post-extrusion process. There are different methods for combining polyethylene molecules during manufacture, which are denoted by PEX-a, PEX-b, and PEX-c. Each letter indicates a different manufacturing process and does not refer to the quality or grade. PEX that complies with ASTM and similar standards is required to be made from specific grades of virgin resin material and that they should contain sufficient UV stabilizers to protect the material during storage and shipping.

The PEX-AL-PEX that APC uses is produced by the PEX-b process. PEX-b is produced by adding silane to the polyethylene. The cross linking process occurs when vinylsilane is added with a catalyst to the polyethylene resin, and then the process is accelerated with heat and moisture. The majority of the cross linking occurs when the piping enters the heated bath part of the process. The PEX-b process is referred to as a moisture cure method of cross-linking PEX.

Cross-linked Polyethylene (PEX) has been used in Europe for hot water heating and plumbing applications for over thirty years and was brought into the US market in the 1980's. Some large manufacturers have over 12 Billion feet Cross-linked Polyethylene (PEX) in service Worldwide (www.ppfahome.org; www.uponor.us.com; Uponor Plumbing Systems Cut Sheet, pg

1). Advances in PEX piping technology lead to the development of PEX-AL-PEX, which will be discussed in detail in the next section. PEX-AL-PEX was brought to the US market in the early 1990's and has become a popular alternative to traditional piping.

Multi-Layer PEX (PEX-AL-PEX)

PEX-AL-PEX is a multi-layered composite tube consisting of an extruded inner core of PEX, a thin layer of aluminum, and an outer extruded covering of PEX as shown in **Figure 3**. The PEX layers are bonded to the inner layer of aluminum using a melt adhesive as part of the extrusion process.

Figure 3 – Multi-layer polyethylene pipe construction

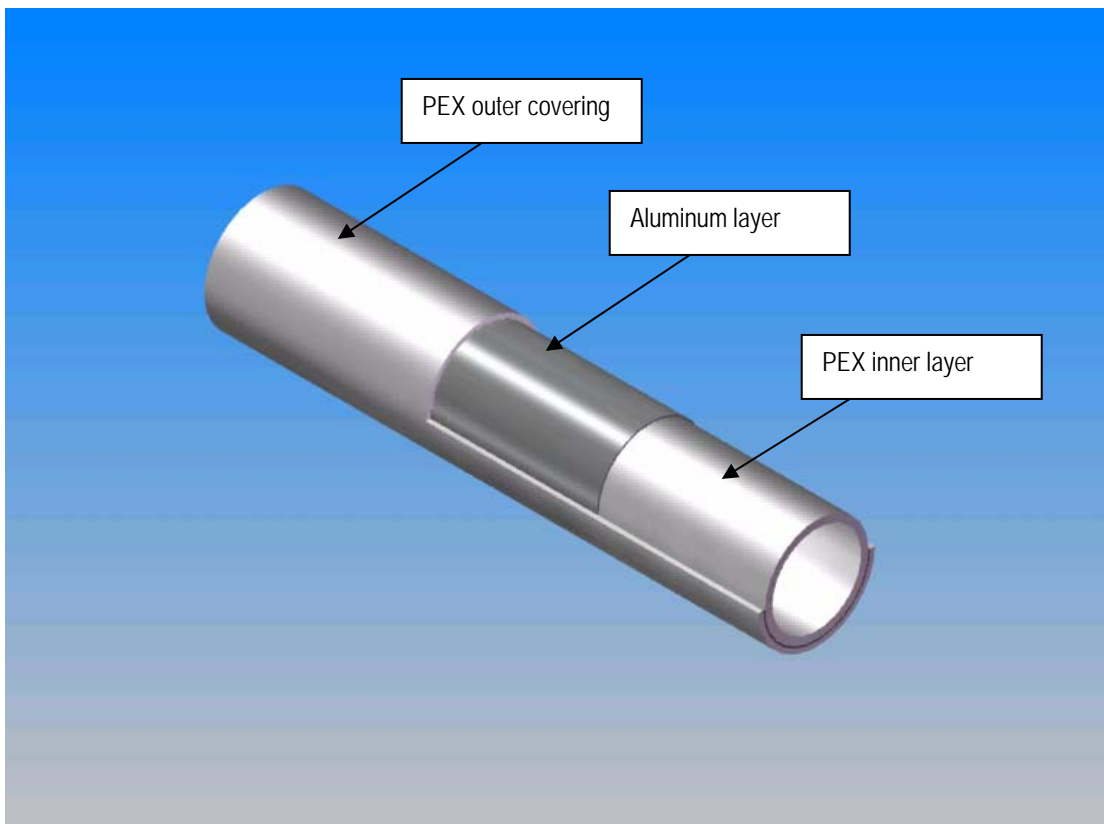

The aluminum layer between the PEX allows it to be bent into an arc, retain its shape, and prevents kinking. This unique property allows tight bends to be made without the use of fittings which reduces the overall joint count in a typical installation and is a major reason that APC selected this type of material for its distributing chilled water to its modular In Row cooling products. The aluminum layer keeps the piping from returning to its original coiled shape, which makes installation easier and requires fewer fixtures to hold the PEX-AL-PEX in place. The Aluminum layer also makes the piping resistant to oxygen

diffusion into the water which helps prevent corrosion of any ferrous components in the piping system. The polyethylene is compatible with water and water/glycol based coolants. It has superior resistance to chemicals and broader range of pH levels over traditional copper or steel pipe plumbed water systems. PEX standards require specific testing to ensure its resistance to residual free chlorine.

The material thickness and physical construction are defined by different standards depending on the type of piping and the standard organization. An example of the tube construction that complies with ASTM F 1281 would have the dimensions listed in **Table 1**. Note that the layers must all add up to a minimum thickness of 2.9 mm (0.114 in.) for a nominal 2632 mm (1 in.) pipe.

Table 1 – 2632mm (1 in) nominal PEX-AL-PEX dimensions per ASTM F 1281-05

	PEX outer layer	Center layer	Inner layer	Total wall thickness minimum	Burst pressure at 23°C (73.4°F)	Sustained pressure for 10 h at 82°C (180°F)
Dimensions	0.40 mm (0.016 in)	0.28 mm (0.011 in)	1.2 mm (0.047 in)	2.9 mm (0.114 in)		
Material	PEX-a,b, or c	100MPa (14,600psi) tensile strength Aluminum	PEX-a,b, or c		4000 KPa (580 psi)	2720 KPa (395 psi)

PEX-AL-PEX utilizes two major styles of fittings to connect it to traditional plumbing pipe thread or solder connections. Both methods require a clean perpendicular cut with a chamfered inner edge to create a leak free joint. APC installers have the specialized tools as shown in **Figure 4** to make the insertion of the PEX-AL-PEX simpler and help ensure the pipe properly seats into the fitting.

Figure 4 – PEX installation tools: shear cutter and chamfer tool

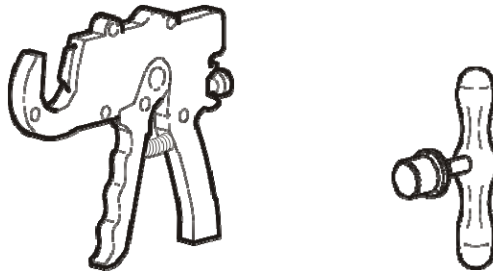

APC utilizes the type of PEX-AL-PEX fitting shown in **Figure 5**. It has a stainless steel press ring which is compressed by electrical driven steel jaws to attach the ring permanently to the PEX. **Figure 6** illustrates the battery powered tool required for

2632 mm (1 in.) and larger PEX-AL-PEX fittings and pipe. The press tool allows the APC installer to make consistent leak free joints. This is accomplished because the press tool controls the strength at which the jaws compress the stainless steel ring, disengaging the pressure when the ring has been fully compressed. This fitting is superior to other designs because it eliminates any variation in the joint quality caused by the physical strength of the operator and is simple to operate. The battery press tool saves time and only requires the operator to lift and position a 6.8 kg (15 lb) press tool. Because the press style fitting makes a permanent connection, union fitting couplings are important for installations where equipment will be moved and lines may be reconnected. All CDU and ACRC equipment comes supplied with union fitting couplings from the factory. This type of fitting is available to mate to most common thread standards and solder connection joints.

Figure 5 – PEX-AL-PEX example of press style of fitting

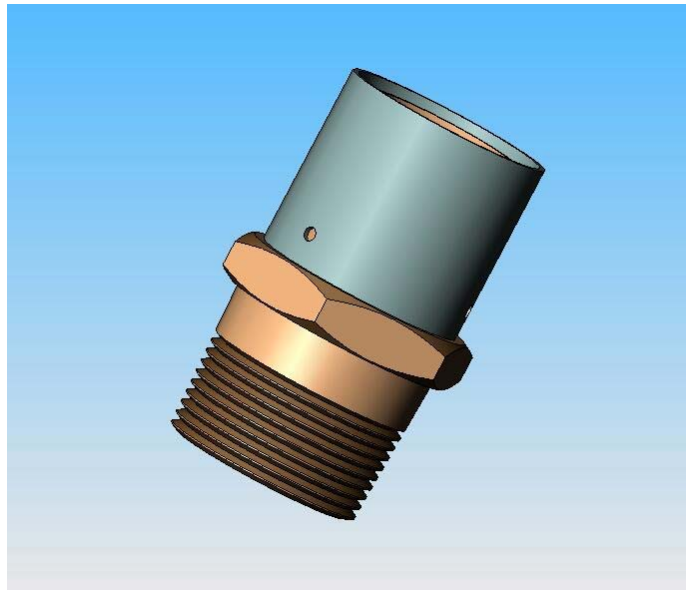
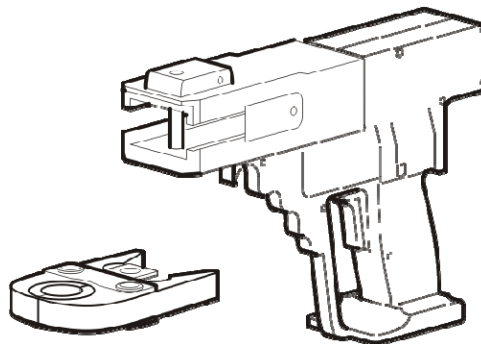
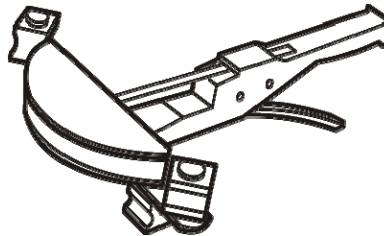

Figure 6 – Press fitting tool with jaws



One of the unique features of cross-linked PEX is its ability to be bent into place which avoids adding a joint at every turn. PEX-AL-PEX has the functionality of not only being bent, but retaining its shape. It can be bent either by hand or using a bending spring or mechanical bender as shown in **Figure 7**.

Figure 7 – Mechanical pipe bending tool



The mechanical bender that APC uses provides a tight bend radius as shown in **Table 2**, which lists the typical bend radius information for a nominal 2632 mm (1 in) pipe. Mechanical bending tools must be used to prevent kinks when making tight bends. It is important to factor in the additional space for insulation to cover the PEX if it is for a chilled water system or if insulation is required to protect it from environmental exposure. The insulation thickness needs to be added to the bend radius during piping design along with an additional length factor to account for any variances in the pipe bend and clearance for installation.

Table 2 – PEX-AL-PEX bend radius including compensation for insulation

Uponor PEX-AL-PEX	Minimum bend radius with REM swing line bend tool mm (in)	Minimum bend radius with bending spring mm (in)	Minimum bend radius using manual bending tool mm (in)
Nominal 2632 mm (1 inch)	179 (7)	179 (7)	204 (8)*

* Not recommended without manual bending tools

In an under floor application with 2632 mm (1 in.) nominal PEX-AL-PEX, a minimum raised floor height of 305mm (12 in.) is required to allow for the required bend radius including the insulation. For overhead applications a minimum overhead clearance of 457 mm (18 in.) is required to allow for the piping, insulation and hangers to be installed.

PEX-AL-PEX mechanical properties

The internal layer of PEX pipe has material properties that help it to resist erosion and scale buildup that can decrease the smoothness of the pipe and increase friction over time. This can be especially beneficial in systems with aggressive water chemistry. Initially, the internal friction characteristics of smooth copper pipe is similar to PEX, but over time the PEX will resist

erosion and scale buildup better than copper, especially in high flow and aggressive water chemistries. **Figure 8** illustrates the pressure drop of a 2632 mm (1 in) nominal diameter PEX-AL-PEX pipe versus the flow rate of the system. This property can be advantageous when designing continuously operating chilled water systems that are space constrained and require high fluid velocities.

Figure 8 – PEX-AL-PEX pressure drop chart

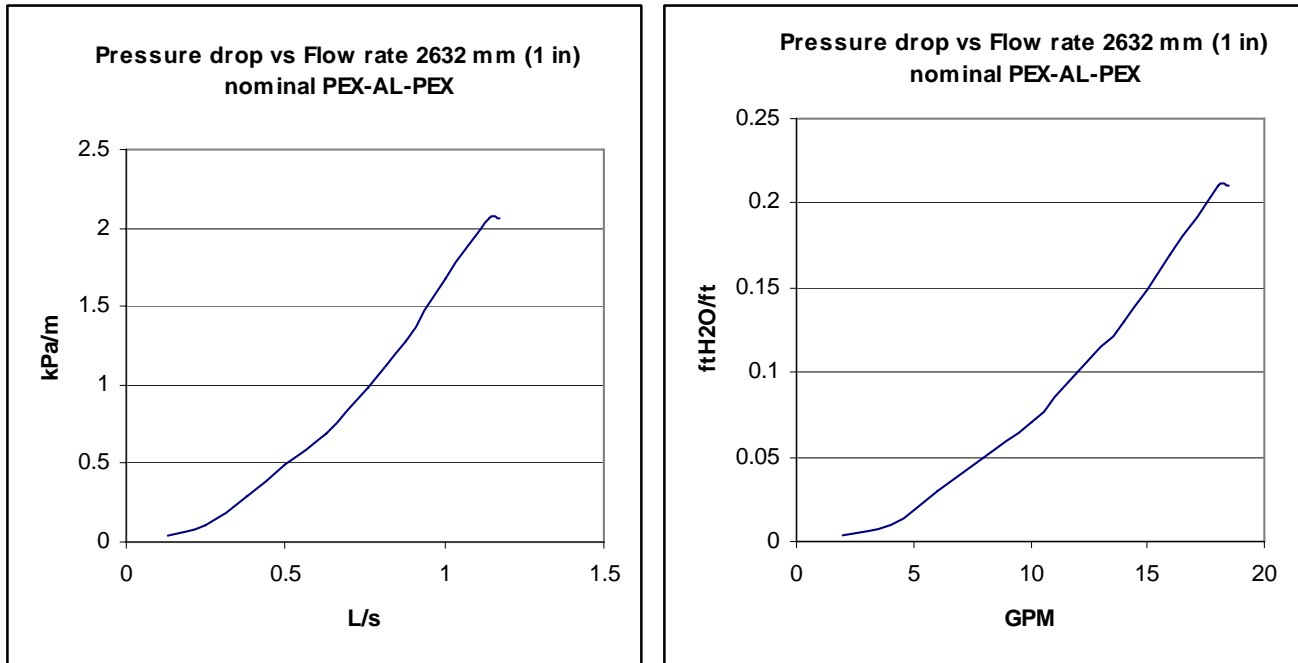

PEX-AL-PEX weighs 50% less than traditional copper water pipe. **Table 3** illustrates the expected weights with and without water or glycol solution per foot of piping for a 2632 mm (1in) nominal tube.

Table 3 – PEX-AL-PEX weight table for 2632mm (1 in) nominal pipe

Uponor PEX-AL-PEX	Weight PEX per unit length kg/m (lbs/ft)	Volume of H ₂ O per length L/100m (gal/100ft)	Weight H ₂ O per unit length kg/m (lbs/ft)	Weight of 40% propylene glycol per unit length* kg/m (lbs/ft)	Weight of 45.7 m (150 ft) span of PEX with 40% propylene glycol solution* kg (lbs)
Nominal 2632 mm (1 inch)	0.324 (0.218)	53.2 (4.28)	0.53 (0.357)	0.552 (0.371)	40.0 (88.4)

* Percentage of Propylene Glycol by mass.

Due to the flexibility of the PEX-AL-PEX piping, it is less rigid than copper pipe and must be supported properly in overhead applications. Support distances vary depending on local codes and it is advisable to consult the most current code for the installation site. **Table 4** lists some of the common spacing minimum distances and the associated standard.

Table 4 – PEX-AL-PEX bend radius

Guideline for PEX-AL-PEX 1 inch (25mm) nominal diameter	Minimum support distance horizontal mm (in)	Minimum support distance vertical mm (in)
International Plumbing Code - Section 308 Piping Support, Table 308.5 Hanger Spacing	813 (32)	1067 (42)
Uponor (Wirsbo) Multi-layer Composite Piping Systems Installation Guide installation manual	1600 (63)	1600 (63)
IAPMO/ANSI UPC 1-2003 - Uniform Plumbing Code Table 3-2 Hangers and Supports	2489 (98)	Base and each floor. Provide mid-story guides.

PEX-AL-PEX is not suitable for outdoor use where it will be exposed to ultraviolet (UV) radiation. The materials contain UV inhibitors to protect them during installation and storage, but UV radiation will break down the material over time. One exception to the UV issue is when PEX-AL-PEX is used in an application that requires insulation for prevention of condensation or heat loss. Most insulation materials when properly applied will protect it from exposure to UV. Special care to adhering joints and seams should be made in these types of installations.

APC's PEX-AL-PEX is compatible with glycol and water, which makes it a good choice for systems that are exposed to temperatures that are lower than the freezing point of water. Since the material can be bent and hold its shape, it can be used to create long piping runs with minimal joints, which is why APC chose it for piping the CDU to the ACRC product. The joints are limited to the CDU and RC units. The joint free sections of piping provide a reliability advantage over the installation of traditional copper fittings since there are no soldered joints to fail.

Reliability

In order to help prove the reliability of PEX connections, important studies have been conducted by the plastic piping institute to understand the erosion of the brass fittings over time. In order to understand the wear characteristics, a study was

conducted by the High Temperature Division of the Plastics Piping at Materials Performance Inc. in College Station, TX to estimate erosion based on 40 years of typical service in a single family residence. Average velocities through a 2025 mm (¾ inch) nominal fitting between 4.9 and 6.7 m/s (16 and 22 ft/s) were used, 15,901,570 liters (4,200,750 gallons) of water was flowed through the fitting, and a water temperature of 60C (140F) was maintained. Weight changes of the fittings were recorded at 3785412 liters (1,000,000 gallon) intervals, and indicated an average loss of less than 3% mass for all fittings tested with less than a 1% change in inner diameter. The results showed very little erosion of the fittings and none of the brass insert fittings failed the test. Detailed information on this study can be referenced in the bibliography of this paper.

Corrosion

Some concerns relating to reliability are focused on the potential of galvanic corrosion between the aluminum and brass at the connection joint. The theory behind the issue arises from the expansion and contraction of piping at the fitting joint. The concern is that over time that expansion and contraction from temperature fluctuations will erode the PEX inner or outer layer till the brass or copper either from the crimp ring or inner fitting contacts the aluminum layer.

If the cross-linked polyethylene wore down and the two dissimilar metals contacted each other in the presence of an electrolyte, a galvanic circuit would be formed that could cause corrosion. The more active metal (Aluminum) would become the anode and transfer ions through the electrolyte (water) to the less active cathode (copper or brass) and corrode the anode. The presence of the circulating electrolyte (water) would continue to expose new aluminum anode material and continue the corrosion cycle till the joint failed.

The properly designed connections that APC uses in combination with the PEX-AL-PEX selected, will not have this issue. The way this is prevented is due to the connector fittings that have a stainless steel press ring. The consistency of the press connection is ensured by APC installers using the proper tools, which decreases the chance that the stainless would pierce through the polyethylene into the aluminum. Also, the difference in electrical potential between stainless steel and aluminum is less than that of brass and aluminum. Having a smaller electrical potential difference between the two metals makes the galvanic circuit, if they were to contact each other in the presence of an electrolyte, have less potential to create corrosion. The APC fittings also utilize elastomer filler that prevents the end of the pipe from contacting the brass fitting. The inner layer of PEX is significantly thicker than the outer layer and therefore unlikely to wear through to the brass o-ring and barb fitting. Another important factor when using the PEX-AL-PEX for chilled process fluids is that the likelihood of expansion and contraction of the pipe is greatly reduced because the temperature differences typically vary less than 11 C (20 F) after the initial chiller startup and temperature cycling is minimal.

Expansion

Another good practice when installing APC PEX-AL-PEX is the use of expansion loops or bends to prevent the pipe from expanded and retracting at the joints. Typical 2632 mm (1 in) nominal PEX-AL-PEX has an expansion rate of approximately 4.0 mm (0.156 in) for every 5.5 C (10F) temperature change per 30.5 m (100 ft). By adding a 90 degree bends to form a rectangle or large radius loops into the piping, issues with pipe expansion can be prevented. The width or radius of the loop should be at least 5 times the overall length of the expansion loop.

Velocity

Velocity of the fluid flowing inside the piping should be minimized to prevent unnecessary pressure drop, noise, and erosion. The velocity in the PEX-AL-PEX piping is limited by the ACRC's maximum flow rate, which is 8 ft per second (2.4 m/sec). Detailed information on the ACRC can be found in the InRow RC technical data manual. Assembly APC installers prevent leaks during installation by following good installation practices and using proper PEX fittings and components. It is important to disassemble PEX fittings that are to be near soldered connections to a copper or brass pipe as the heat from the flame could damage them. Pipe threads should use a good pipe sealant to prevent joint leaks. The system should also be pressure tested up to design pressure and given sufficient settling time to determine if it has any leaks per local code or manufacturers recommendations.

PEX-AL-PEX Codes and Standards

Many local plumbing codes restrict the use of cross-linked polyethylene (PEX) tubing from being used for potable water and drains. But PEX tubing used for radiant heating and chilled water piping for air conditioner systems falls under the hydronics section of the Mechanical Code; it does not fall under the plumbing code. Below is a summary from the two common Mechanical Codes, both allowing the use of PEX for hydronic piping.

- The Uniform Mechanical Code (UMC) is published by the International Association of Plumbing and Mechanical Officials (IAPMO). Chapter 12 covers hydronics piping, which is defined as steam and water piping which are part of a heating or cooling system. Section 1201.4 covering PEX tubing States that PEX may be used up to 160 psi (1103 kPa) for water temperatures less than 73°F (23°C). Section 1201.5 covers PEX-AL-PEX tubing allowing it to be used up to 200 psi (1380 kPa) for water temperatures less than 73°F (23°C). Further, the UMC allows mechanical compression fittings and crimp/insert fittings designed for use with PEX. It is worth noting that PEX was only added to the UMC in the 2003 edition, although jurisdictions that use the UMC should have adopted the 2003 edition over the older 2000 edition.
- The International Mechanical Code (IMC) is published by the International Code Council (ICC). As with the UMC, chapter 12 covers hydronics piping. However, the IMC has a different organization within this chapter. Section 1202.4 specifies the acceptable materials for hydronics piping including both PEX and PEX-AL-PEX. The IMC allows the standard compression and crimp/insert fitting. The IMC does not restrict the pressure of PEX tubing; it only requires hydronics systems to be hydrostatically tested at 150% of the system design pressure for 15 minutes.

It is always important to check with local codes before the design and installation of a PEX-AL-PEX system.

DIN, ASTM, and CSA standards are important to insure the quality of the PEX-AL-PEX. These standards are similar in their fundamentals, but will vary on usage by country. Some of the typical PEX-AL-PEX piping standards are:

- F1281-05 Standard Specification for Crosslinked Polyethylene/Aluminum/Crosslinked Polyethylene (PEX-AL-PEX) Pressure Pipe ICBO ER 5298
- SBCCI (PST and ESI Report No. 9661)
- F1974-04 Standard Specification for Metal Insert Fittings for Polyethylene/Aluminum/Polyethylene and Crosslinked Polyethylene/Aluminum/Crosslinked Polyethylene Composite Pressure Pipe
- CSA B137.5, Crosslinked polyethylene (PEX) tubing systems for pressure applications
- CSA B137.10, Crosslinked polyethylene/aluminum/crosslinked polyethylene (PEX-AL-PEX) composite pressure-pipe systems

One of the most critical physical characteristics that are called out by standards are the pressure rating of the piping. PEX-AL-PEX should meet the following or equivalent rating points (values specifically from ASTM F12812-05):

- 1.38 MPa (200psi) at 23°C (73.4°F)
- 1.10 MPa (160psi) at 60°C (140°F)
- 0.86 MPa (125psi) at 83°C (180°F)

Markings on the materials should include the size, material designation, pressure rating, manufacturer's name and standard. The correct markings should also be found on fittings in accordance with the appropriate standard, which will indicate that the fitting is designed for PEX-AL-PEX pipe. Detailed information on materials and testing can be referenced in the ASTM standard listed below.

Bibliography

ASTM Designation: F 1281-05, Standard Specification for the Crosslinked Polyethylene/Aluminum/Crosslinked Polyethylene (PEX-AL-PEX) Pressure Pipe, September 1, 2005.

PPI TN-26/2005, Erosion Study on Brass Insert Fittings Used in PEX Piping Systems, October 2005

<http://www.plasticpipe.org/pdf/pubs/notes/TN-26-2005.pdf>

About the Author:

Matthew Brown is a New Product Development engineer for APC. He is responsible for designing cooling solutions for the Enterprise Systems division of APC. Matt has a Bachelor's degree in Mechanical Engineering from Clemson University and a MBA from the University of South Carolina. He is also a member of ASHRAE.