

## InRow RP-CW and InRow RP-DX Environmental Control

By Henry Jespersen

### Abstract

The primary function of the InRow RP product is to cool air from the hot aisle and deliver it to the cold aisle at the temperature setpoint. The InRow RP controls the environment with four basic functions: cool, reheat, dehumidification, and humidification and various combinations thereof. The control strategy employed depends upon the deployment strategy of the cooling group. For the In-row (open aisle) environment, the InRow RP supplies constant-temperature supply air to the common cold aisle. The fan speed is modulated to ensure that the desired volume of air reaches the IT equipment. For hot aisle containment (HACS) or rack air containment (RACS) environments, the InRow RP neutralizes the heat accumulated in the common hot aisle and expels it back into the surrounding environmental space while maintaining the desired temperature in the cold aisle. This application note describes the control process for the InRow RP.

## Introduction

In order to provide environmental control, the InRow RP units monitor the temperature and humidity of the return air, temperature and humidity of the supply air, and three remote rack inlet temperatures. The remote rack inlet temperature sensors are only used for In-row (open aisle) mode. The InRow RP chilled water (CW) unit monitors the inlet fluid temperature, outlet fluid temperature, and fluid flow rate. The InRow RP air-cooled DX unit monitors compressor suction and discharge pressures. This unit also monitors several other attributes to determine the health of the system and provide alarms under adverse conditions.

The InRow RP ensures proper server inlet temperatures by actively controlling cooling capacity. The unit adjusts cooling capacity in response to thermal changes within the row of IT equipment to maintain rack inlet temperatures 7 X 24. The Active Response Controls of the InRow RP ensures that servers consistently operate at the desired rack inlet setpoint, which can be configured to be between 68-77°F (20-25°C) as recommended by the Thermal Guidelines for Data Processing Environments provided by ASHRAE.

The InRow RP continually adjusts its cooling output to accommodate varying loads. The cooling output is determined by the difference between the supply air temperature setpoint and the actual supply air temperature as well as the airflow (for each of the cooling units in the cooling group if more than one cooling unit is present).

## InRow RP Environmental Models

### In-row (open aisle) model

*Figure 1 – In-row (open aisle) environmental model*

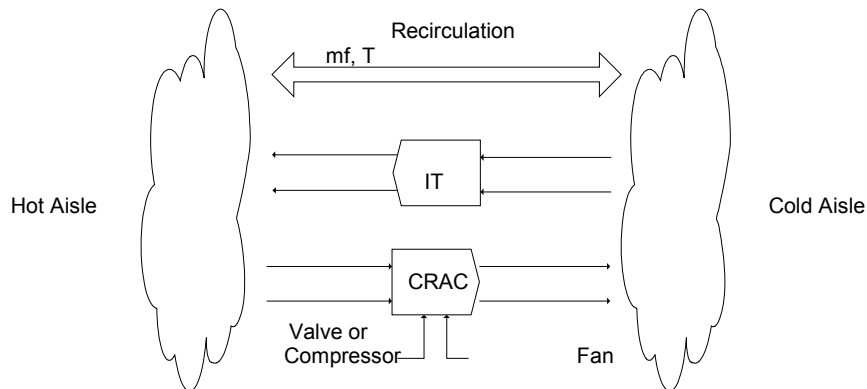

The In-row (open aisle) model is characterized by the free circulation of air, quantified by  $mf$  (mass flow) and  $T$  (temperature). The IT equipment draws in cool air from the cold aisle and rejects it to the hot aisle. The CRAC takes hot air from the hot aisle and supplies cool air to the cold aisle. There may be mixing of the cold and hot aisles over the top of the racks, around the sides, etc.

### Hot aisle containment system (HACS) model

*Figure 2 – HACS environmental model*

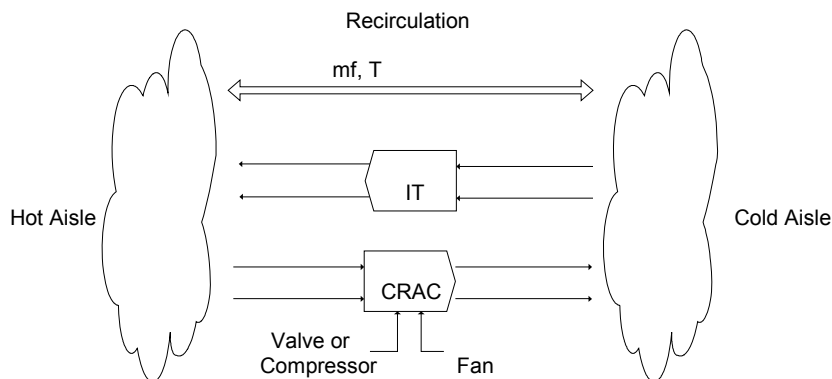

The hot aisle containment system (HACS) model is similar to the In-row model, except that the amount of recirculation is drastically reduced.

### Rack air containment system (RACS) model

*Figure 3 – RACS environmental model*

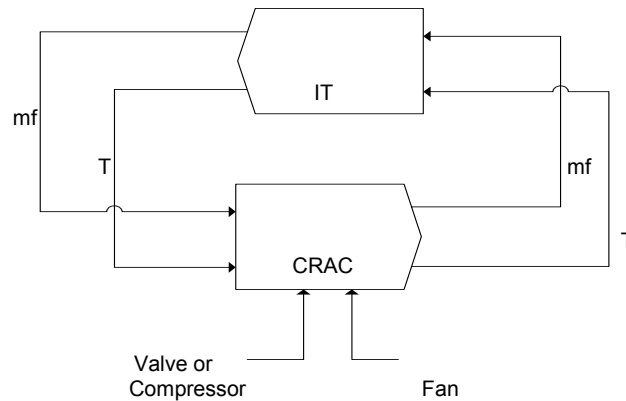

The rack air containment system (RACS) model is characterized by the direct coupling of the CRAC to the IT equipment. The environment is semi-sealed such that mixing of cold and hot air is minimized.

## InRow RP Environmental Control Functions

### Cooling

The InRow RP continually adjusts its cooling output to accommodate varying loads. The InRow RP-CW controls a fluid valve to modulate the fluid flow into the cooling coil. The InRow RP-DX modulates the compressor speed, varying the compression ratio and mass flow to the direct expansion coil. The cooling output is determined by the difference between the supply temperature setpoint and the actual supply temperature (for each of the cooling units in the cooling group if more than one cooling unit is present). The reheat function may be used in conjunction with the cooling function to allow lower cooling outputs than are possible with the cooling function alone. Use of the heaters while the cooling function is active can be enabled or disabled by a user settable configuration setting. If enabled, the reheat output is set as low as possible to provide for proper cooling control, so as to minimize the power consumption of the unit

### Humidification

Humidity is managed using dewpoint control. Humidity readings and setpoints are shown in %RH but are converted to dewpoint internally for control. The InRow RP contains an electric steam grid humidifier that injects steam into the air if the humidity is below the humidify setpoint. The output for humidification is determined by the difference between the humidify setpoint and the average return air humidity of all the units in the cooling group (if more than one unit is present).

**Dehumidification**

Humidity is managed using dewpoint control. Humidity readings and setpoints are shown in %RH but are converted to dewpoint internally for control. The InRow RP is capable of actively removing humidity from air passing through the unit. Dehumidification is determined by the dehumidify setpoint and the average return air humidity of all the units in the cooling group (if more than one unit is present). Dehumidification is a discrete on / off function - when dehumidification is active, the dehumidification process output is 100%.

**Reheat**

The reheat option heats the air leaving the cooling coil if the return air temperature of the cooling unit drops below the reheat setpoint. This is achieved by energizing finned tubular electric resistance elements and may happen while the unit is dehumidifying or if no IT equipment is running in a cold climate. The reheat output will increase as the return air temperature decreases.

**Heat assist**

The Heat Assist function is enabled or disabled by a user selectable configuration setting. If Heat Assist is enabled, then:

- Reheat is used as needed during cooling (DX only) to provide stable control at lower cooling outputs (low heat load conditions) than is possible with cooling alone.
- Reheat is used during dehumidification (CW and DX) to increase the unit's ability to dehumidify.

**Multiple control functions**

More than one control function can be active at the same time. The following combinations of active control functions are possible.

- Cool
- Cool and reheat (Heat Assist for lower cooling output)
- Reheat
- Humidification
- Dehumidification
- Cool and humidification
- Dehumidification and reheat
- Humidification and reheat

## InRow RP Airflow Management

Changes in fan speed are limited to a maximum of 2% per second at all times. This limitation prevents the unit airflow from changing too quickly when the operating mode or active environmental control function changes, thereby improving control stability.

## InRow RP-CW Cooling Control

### Chilled water supply temperature control

The supply temperature controller regulates the chilled water (CW) valve and is responsible for maintaining the leaving air temperature at the desired set point. This works identically for InRow, HACS, and RACS. Minimum valve position is where there is essentially no flow through the coil. By preventing the valve from closing entirely while in operation, the unit can be more responsive to increases in heat load. The valves' maximum position is where there is no additional flow through the coil. By limiting the maximum position, the controls can respond faster to a drop in the heat load.

## InRow RP-DX Cooling Control

### Direct expansion supply temperature control

The supply temperature controller regulates the compressor speed through the use of a VFD and is responsible for maintaining the leaving air temperature at the desired set point. This works identically for In-Row, HACS, and RACS. The compressor speed may vary from 35 Hz to 85 Hz. The compressor will be cycled Off and On as needed to avoid over-cooling which could result in coil icing or excess condensation.

### DX heat assisted cooling (low cooling output operation)

If the Heat Assist function is enabled (a user selectable configuration setting) the unit will turn on the reheat as needed during cooling, providing an additional 'false' heat load, to better allow the supply temperature controller to maintain a stable supply air temperature during low heat load conditions. This provides for a lower cooling output than would otherwise be possible with cooling alone and further minimizes the potential for compressor cycling during low heat load conditions.

### DX compressor management

**Compressor cycling timers** – a 2 minute Minimum Compressor Off time and a 3 minute Minimum Compressor On time are employed to prevent excess compressor cycling whenever possible.

**Oil return mechanism** – an oil return mode is employed to properly circulate the refrigerant oil within the system. This is accomplished by limiting the time the compressor will continuously run at a low speed. If the compressor speed is below 50 Hz for 30 minutes continuously then the minimum compressor speed is forced to 50 Hz for two minutes whenever possible.

**Suction and discharge pressures** – the compressor speed and / or unit airflow is dynamically reduced as needed to maintain the suction and discharge pressures within the acceptable range. The compressor speed can be reduced down to the 30 Hz minimum. The fan speed can be reduced down to the minimum speed of 30%.

**Safety shutdown** – if the suction or discharge pressure is not within a safe range the compressor will be turned off to avoid potential damage to the refrigeration system.

## InRow RP Control Setpoints (Mode Dependencies)

Mode	Cooling setpoint	Supply air setpoint	Fan speed preference
In-row	Set desired Maximum Rack Inlet Temperature	Set desired Supply Air Temperature	No effect
HACS	No effect	Set desired Supply Air Temperature	Set desired Delta-T (Return to Supply Air Temperature)
RACS	No effect	Set desired Supply Air Temperature	Set desired Delta-T (Return to Supply Air Temperature)

## InRow RP Control Models

In-row (open aisle) mode

Figure 4 – In-row (open aisle) control response

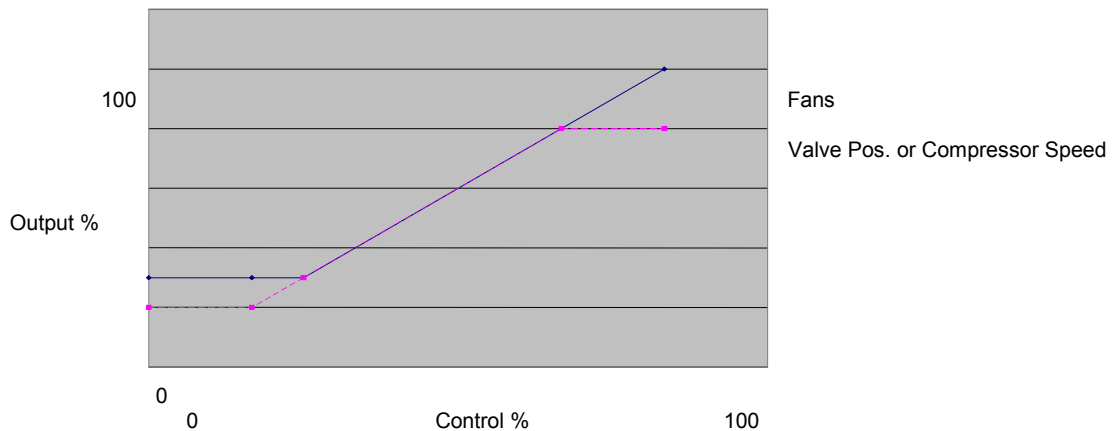

### Fan control

In this design, illustrated in **Figure 4**, the mass airflow is determined by T (remote), which is the maximum reading of the unit's three Remote Temperature Sensors. The minimum fan speed is 30%. This speed was chosen to prevent fan bearing wear, and to ensure that there is always some airflow over the temperature sensors so that readings are accurate.

### Supply air temperature control

The chilled water valve (RP-CW) or compressor (RP-DX) is controlled by the supply temperature controller which is responsible for maintaining the leaving air temperature at the desired set point. The controller's input is the leaving air temperature  $T_{\text{supply}}$ , measured by the integral supply temperature sensor, and its output is a commanded valve position (RP-CW) or commanded compressor speed (RP-DX). The design of the supply temperature controller is the same for all rack configurations.

### HACS and RACS modes

*Figure 5 – HACS / RACS control response*

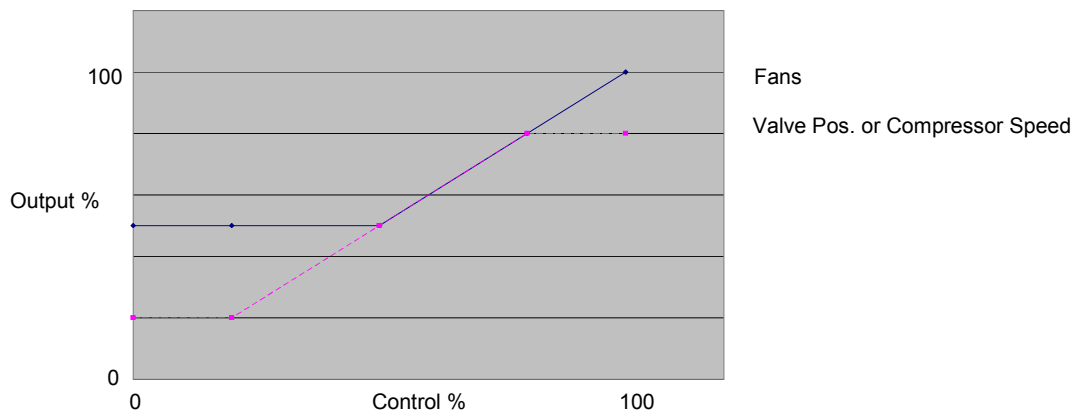

### Fan control

HACS and RACS environments are controlled by the same control strategy. In a HACS or RACS environment, the primary goal is to control the temperature and movement of the contained air by maintaining a temperature gradient across the unit. This temperature gradient ( $\Delta T$  value) is the difference between the unit's return air temperature and its supply air temperature. The remote rack inlet sensors are not used in HACS or RACS mode. The following table describes how the user-specified Fan Speed Preference relates to a given  $\Delta T$  value:

Fan Speed Preference Setting	$\Delta T$
High	10
Med High	15
Med	20
Med Low	25
Low	30

The minimum fan speed is 40%. This speed was chosen to prevent fan bearing wear, and to ensure that there is always some airflow over the temperature sensors so that readings are accurate. This speed is slightly higher than the In-Row minimum speed; the higher speed helps stabilize the supply temperature in lower load conditions.

#### Supply air temperature control

The supply air temperature control for a HACS or RACS environment is identical to the supply air temperature control used in the In-Row environment.

## InRow RP Dehumidification Control

Humidity control is based on the return air dewpoint. Dehumidification is under discrete control (a unit's dehumidification output is either 0% or 100%). A unit enters dehumidification when the dewpoint rises above the dehumidification setpoint plus dead band. The cooling demand must be satisfied, and the fan speed must be below 80% to provide headroom for cooling. When dehumidification is active the fan speed is constant at 40%. The unit leaves dehumidification if the dewpoint drops below the dehumidification setpoint, the maximum rack inlet temperature rises excessively (In-Row mode), or the return air temperature rises excessively (RACS or HACS mode).

#### ***Dehumidification – heat assist function disabled***

The supply temperature controller setpoint is reduced to 62°F or the supply air dewpoint + 3.6°F, whichever is higher.

#### ***Dehumidification – heat assist function enabled***

Reheat output is gradually increased until the supply temperature controller is near its maximum output. As more heat is added, the supply temperature controller will compensate by opening the valve (RP-CW) or increasing the compressor speed (RP-DX) in order to maintain the supply temperature setpoint configuration setting. This results in the air temperature leaving the coil being as cold as possible while still maintaining the unit's supply temperature at the supply temperature setpoint setting. Reheat output is gradually decreased if the supply temperature controller's output gets to close to its maximum.

## InRow RP Humidification Control

Humidity control is based on the return air dewpoint. The Humidification Output Controller provides the humidify demand for the unit. The input is the average return air dewpoint. When only humidification is active the fan speed is a constant 50%. If cooling or reheat is active while humidification is active, the minimum fan speed is 50%.

## InRow RP Reheat Control

The Reheat Output Controller provides the reheat demand for the unit. Reheat output is determined by the unit's return air temperature. When only reheat is active or only reheat and humidification are active, the fan speed is a constant 60%. If dehumidification is active while reheat is active, the fan speed is a constant 40%.

## InRow RP Latent Cooling Control

The presence of water droplets in the leaving (supply) air due to excessive condensation is prevented by limiting latent cooling. If the supply air humidity is above 64%RH, the latent cooling reduction controller will dynamically adjust the operating supply temperature setpoint upward from the configured supply temperature setpoint as needed to limit latent cooling.

## InRow RP Group Control Model

The goal of this model of group control is to stabilize unit interaction while still providing adequate temperature and humidity control of the environment. Independent of rack configuration, the units in a group operate in a master/slave relationship. One unit is elected to perform the duties of the group master without user intervention. In the event the master unit fails one of the slave units will become the new group master without any user intervention. If a temperature or humidity sensor of a unit fails, it will not be considered by the master unit's group control.

## InRow RP Group Cooling Control

### In-row mode

#### Fan control

In an In-Row configuration, all the units in the group control their fans to the output of the master unit's fan controller. The master unit uses its own and each slave unit's remote temperature sensor readings to determine the maximum group rack inlet temperature,  $T_{MAX}$ , and uses this value as the input to its fan controller. The master sends the fan controller's output to all the slave units, which is then used by the slave unit's to control their fan speed rather than the output of their own fan

controller. This approach assures even air distribution and circulation through the space rather than independent airflow patterns that would influence other units and cause instability.

### **Supply air temperature control**

Each unit controls their chilled water valve (RP-CW) or compressor (RP-DX) independently based on their own supply temperature sensor reading. In a group configuration the supply temperature setpoint is shared among all the units, with each unit managing its own chilled water valve or compressor based on its own supply temperature. Thus there is no need for group control of the supply temperature.

## HACS and RACS modes

### **Fan control**

In a HACS or RACS configuration all the units in the group calculate their unit power demand based on their own return temperature sensor reading. The demand from each unit is sent to the group master unit. The master unit uses the demand from all the units to calculate an average power demand. The master sends this average power demand to all the slave units and each unit uses this value to control their own fan speed. This approach assures even air distribution and circulation through the space rather than independent airflow patterns that would influence other units and create instability.

### **Supply air temperature control**

Each unit controls their chilled water valve (RP-CW) or compressor (RP-DX) independently based on their own supply temperature sensor reading. In a group configuration the supply temperature setpoint is shared among all the units, with each unit managing their own chilled water valve or compressor based on their own supply temperature. Thus there is no need for group control of the supply temperature.

## InRow RP Group Humidity Control

### Group dehumidification control

Group dehumidification control is based on the average of all the unit's return air dewpoint. Whenever additional dehumidification is needed the group master unit determines which unit will enter dehumidification mode. Only one additional unit is allowed to enter dehumidification at a time. If there is a cooling demand on any unit in the group, the group controller will inhibit dehumidification on all the units in the group for 15 minutes.

### Group humidification control

Group humidification control is based on the average of all the unit's return air dewpoint. The group master unit calculates the average of all the unit's return air dewpoint and provides this value to all the units in the group. Each unit's humidification controller uses this group average return air dewpoint. Since the humidification controller uses proportional-only control, each unit in the group will provide the same humidification output.

## InRow RP Group Reheat Control

Group Reheat control is the same as for a stand-alone unit. Each unit independently controls its own heaters.

## InRow RP Group Latent Cooling Control

Group latent cooling control is the same as for a stand-alone unit. Each unit in a group will independently control its latent cooling reduction as needed to avoid excessive condensation in its leaving (supply) air.

## InRow RP Startup Time

The unit Startup time is the delay period from power-up until normal environmental control ensues. It determines the power outage recovery time once power is reactivated. During the delay period, the system performs self diagnostics and determines its state of health. The Startup times are as follows:

- CW Startup Time = *Startup Delay* + 15 seconds
- DX Startup Time = *Startup Delay* + 40 seconds

where, *Startup Delay* is a user selectable unit configuration setting which provides a mechanism to restart multiple units sequentially.

## InRow RP Fault Handling Strategy

Cooling is a higher priority than humidity control or reheat control. The primary failure mode strategy is that a unit should provide cooling if possible and that providing more cooling than needed is acceptable to ensure adequate cooling to the IT equipment. When cooling is not possible, the dumping of hot air into the cold aisle is minimized by shutting Off the fans.

### Alarms

When an abnormal condition or fault is detected the unit will generate an alarm. When the condition no longer exists the unit will clear the alarm without any user intervention. Alarms are categorized as either a warning or a critical alarm. If the condition causes the unit to shut down or otherwise results in an impaired environmental function (temperature or humidity control) then a critical alarm is generated, otherwise a warning alarm is generated. There are also informational events that do not have an associated alarm but that are created in the event log.

For a detailed description of all the supported alarms and their recommended actions, refer to the appropriate InRow-RP-CW or InRow RP-DX Users Guide.

## Unit shutdown causes

The following failure conditions will shut down the unit, thereby changing the unit's operating state to Idle or Standby.

### Remote shutdown

When the Remote Shutdown discrete input is active, the unit will go into Standby, ceasing all environmental control.

### Cooling failure

This condition occurs when the supply temperature of the unit exceeds 77°F (25°C) and the cooling output is too low for a period of time. After a cooling failure occurs, the unit goes into the Idle state. The fans are turned Off and the valve is completely closed (CW) or the compressor is shut Off (DX). Periodically, a cooling retry is initiated which turns the fans On (minimum speed) and activates the supply temperature controller. If the temperature still remains above 77°F (25°C), the fans are turned Off and the valve is completely closed (CW) or the compressor is turned Off (DX). Once the temperature drops below 77°F (25°C) during the cooling retry, the unit can go into the On state and perform normal environmental control.

### Condensate pump fault

This condition occurs when the condensate pump fails. It is cleared automatically when the condensate pump is operating correctly. When this fault condition occurs, the fans are turned Off, the CW valve is closed completely (CW) or the compressor is turned Off (DX), and the unit goes into the Idle state. This prevents any further condensation which could cause the condensate pan to overflow. When this fault is cleared the unit can go into the On state and perform normal environmental control.

### Leak detection shutdown

This condition is active when a leak is detected at a unit, and the unit setting "Shutdown on Leak Detect" is set to enabled. It is automatically cleared when the leak is no longer detected. When this fault condition occurs, the fans are turned Off, the CW valve is closed completely (CW) or the compressor is turned Off (DX), and the unit goes into the Idle state. When this fault is cleared, the unit is allowed to go into the On state and perform normal environmental control.

## About the Author:

**Henry Jespersen** is a Senior Firmware Engineer for APC. He is responsible for designing and implementing embedded controls for IT equipment cooling products. Henry received a Bachelor's degree in Electrical Engineering from Fairleigh Dickinson University in 1990.