

Comparison of Static and Rotary UPS

By Carl Cottuli

Jean-Francois Christin

White Paper #92



Executive Summary



Much confusion exists among data center professionals when deciding whether to deploy static or rotary Uninterruptible Power Supplies (UPS) in their data centers. This paper defines both static and rotary UPS architectures, points out similarities and differences, and analyzes the advantages and disadvantages of each in data center environments.

Introduction

Most of the information about static and rotary UPSs available in the public domain is technically complex and difficult to absorb. Fortunately, much research has been conducted addressing this topic and this paper attempts to present these technologies in a straightforward manner.

UPSs vary greatly in physical size, weight, form factor (e.g., standalone vs. rack-based), capacity, supported input power source (e.g., single phase vs. 3-phase), technological design, and cost. The focus of this paper will be limited to comparing 3-phase static and rotary UPSs that support data centers. **Table 1** highlights some of the common static and rotary UPS architectures.

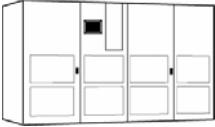
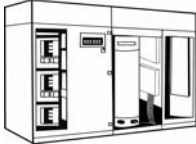
Table 1 – Comparison of static and rotary UPS architectures

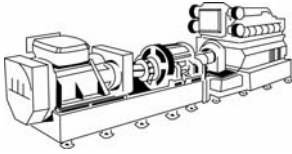
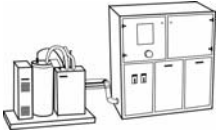
Static	Key Differentiators	Rotary	Key Differentiators
 <p>Double-Conversion UPS</p>	<ul style="list-style-type: none"> - Represents > 90% of 3- phase UPS installed base - Supports wide load range (10 kW – 1.6 MW) - Typical runtimes 5 to 15 minutes 	 <p>Motor-generator / battery UPS</p>	<ul style="list-style-type: none"> - Compact vertical motor / generator design - Outputs power through motor / generator - Mechanical components / higher maintenance
 <p>Delta Conversion UPS</p>	<ul style="list-style-type: none"> - Highest Efficiency - Modular/ scalable - Electrical components / lower maintenance 	 <p>Engine Coupled UPS</p>	<ul style="list-style-type: none"> - Attached / integrated diesel generator - Mechanical components / higher maintenance - Single unit supports largest load blocks (1 MW +)
 <p>Flywheel UPS</p>	<ul style="list-style-type: none"> - Battery free - Typical runtimes 15 - 30 secs - Represents < 3% of 3-phase UPS installed base - Outputs power through inverter 		

Efficiency Considerations

When discussing UPS efficiency, it is important to define what is meant by the term “efficiency”. The definition of UPS efficiency has to be consistent with the way efficiency is defined for the entire data center. Data center efficiency is measured as the ratio of watts to the IT load / watts to the data center (see APC White Paper #154, “[Electrical Efficiency Measurement for Data Centers](#)” for more details). This metric is

referred to as the Data Center Infrastructure Efficiency (DCiE) measurement. If 100 watts of power enter the data center and only 60 of those watts make it to the IT load, then that data center is 60% efficient (60/100 = 60%). Of the power coming into the UPS, what percentage makes it to the load? If UPS fixed losses, proportional losses, and square law losses are accounted for, the rest of the power is delivered straight to the load. Thus, if a UPS is 85% efficient, 15% of the power coming into the UPS never makes it to the load.

Figure 1 compares the efficiency curves of modern static and rotary UPS. When analyzing the efficiency curves, the following points need to be considered:

- data centers rarely, if ever, run their UPSs at 100% load
- the majority of UPSs run below 80% of load and are most often run between 45 - 55% of load
- data centers running redundant UPSs typically run each of those UPSs at 30 to 50% of load

Figure 1 – Static and rotary UPS efficiency comparison

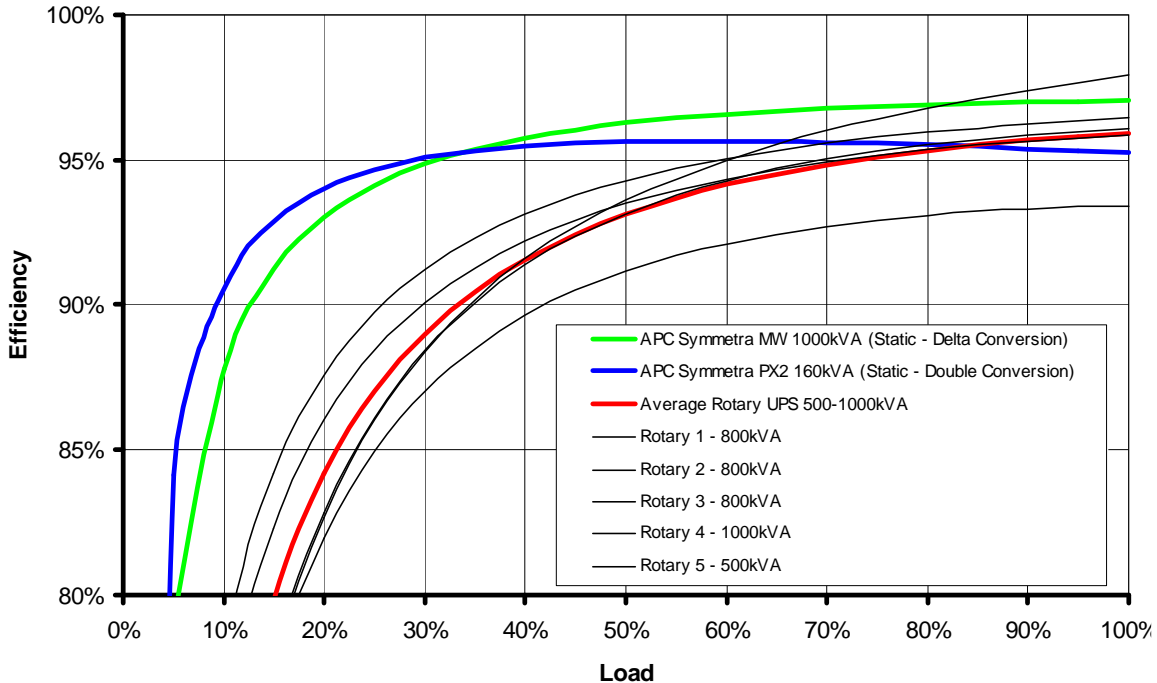

The curves in **Figure 1** reveal that both static UPS topologies run more efficiently than their rotary counterparts over the entire normal operating range with a very significant advantage below 50% load. The shapes of these curves suggest that rotary UPSs sustain higher fixed losses. Examples of these rotary UPS fixed losses include the energy utilized to power controls, flywheels, and pony motors associated with the rotary UPS at zero load and the energy utilized to preheat the engine coolant and lubrication. Frictional and windage losses also have an impact on the overall efficiency. These losses are referred to as standby losses and they represent the amount of energy required to keep a motor running or to keep a flywheel spinning.

Consider the impact of these efficiency curves on the energy and environmental cost of both a static and rotary UPS. Assume a double conversion static UPS (the green curve in **Figure 1**) and an average rotary UPS (the red curve in **Figure 1**) running at 35% of capacity (a common capacity rate in a typical 2N UPS environment). At 35%, the double conversion static UPS is 95% efficient (experiences a 5% loss). The rotary UPS, on the other hand, is 90% efficient (experiences a 10% loss). Assume that each UPS is supporting a 2 MW (2,000 kW) load, and assume an average electrical rate of \$.13 per kilowatt over a 10 year lifecycle.

Static UPS loss calculation:

(Note: to support a 2000 kW IT load, this UPS running at 95% efficiency must draw 2105 kW from the utility)
2105 kW, which is utility power required for the load, x .05, which is the efficiency loss, = 105 kW (loss)
105 kW x 8,760 hours = 919,800 kW / hrs per year
919,800 kW / hrs per year x 10 years = 9,198,000 kW-hours over the lifecycle time period
9,198,000 kW-hours x \$.13 (assumed cost of electricity per kW / hr) = **\$1,195,740** in losses

Rotary UPS loss calculation:

(Note: to support a 2000 kW IT load, this UPS running at 90% efficiency must draw 2,222 kW from the utility)
2222 kW, which is the load, x .10, which is the efficiency loss, = 222 kW (loss)
222 kW x 8760 hours = 1,944,720 kW / hrs per year
1,944,720 kW / hrs per year x 10 years = 19,447,200 kW-hours over the lifecycle time period
19,447,200 kW-hours x \$.13 (assumed cost of electricity per kW / hr) = **\$2,528,136** in losses

Every watt of power being brought into the site represents a watt of waste heat that needs to be removed; heat removal costs also need to be considered when evaluating long term costs. Various heat removal implementations can be utilized based upon the type of UPS installed. Static UPSs and motor-generator / battery rotary UPSs will often utilize either Computer Room Air Conditioners (CRACS) and / or a water side or air side economizer for heat removal. Engine-coupled rotary UPSs would require the utilization of a system of louvers, ventilators and / or fans to help in the heat removal process. Regardless of the method utilized, the heat removal represents an energy cost which is once again impacted by the UPS efficiency.

The net difference in losses cited above for the static UPS compared to the rotary UPS over the 10 year lifecycle is **\$1,332,396** in favor of the static (\$2,528,136 - \$1,195,740). In effect, when comparing the static and the rotary UPS in our example, the net difference in losses would have to be doubled to factor in the heat removal. This would increase the net difference in losses to **\$2,664,792**. The static also represents a net avoidance of **12,298** metric tonnes in carbon emissions (for both the extra power and cooling consumption), which is equivalent to running **2,705** fewer cars on the road.

Static UPS and Rotary UPS Defined

The static UPS is called “static” because, throughout its power path, it has no moving parts (although it has auxiliary moving parts, such as cooling fans). A typical static UPS consists of the components shown in **Figure 2**. Double-conversion topology is shown because it is the most common design.

The rectifier inside of the static UPS converts the incoming utility AC current to DC, and the inverter converts DC back to clean sine-wave AC to supply the load. Regardless of the details of the internal topology, at some point there is a place where DC current interfaces with the “energy storage” medium – most commonly batteries, in which case it charges the batteries and receives power *from* the batteries when the utility power supply is distorted or fails.

A data center 3-phase static UPS typically has a battery backup time (“runtime”) of 5 to 30 minutes (this can vary widely depending upon application). This runtime is calculated based upon the size and criticality of the load and the available battery capacity. Static UPS battery systems are generally sized to allow enough time, during an outage or disturbance, to support the load while the power source shifts from utility to a standby generator.

Figure 2 – Static UPS using batteries for energy storage

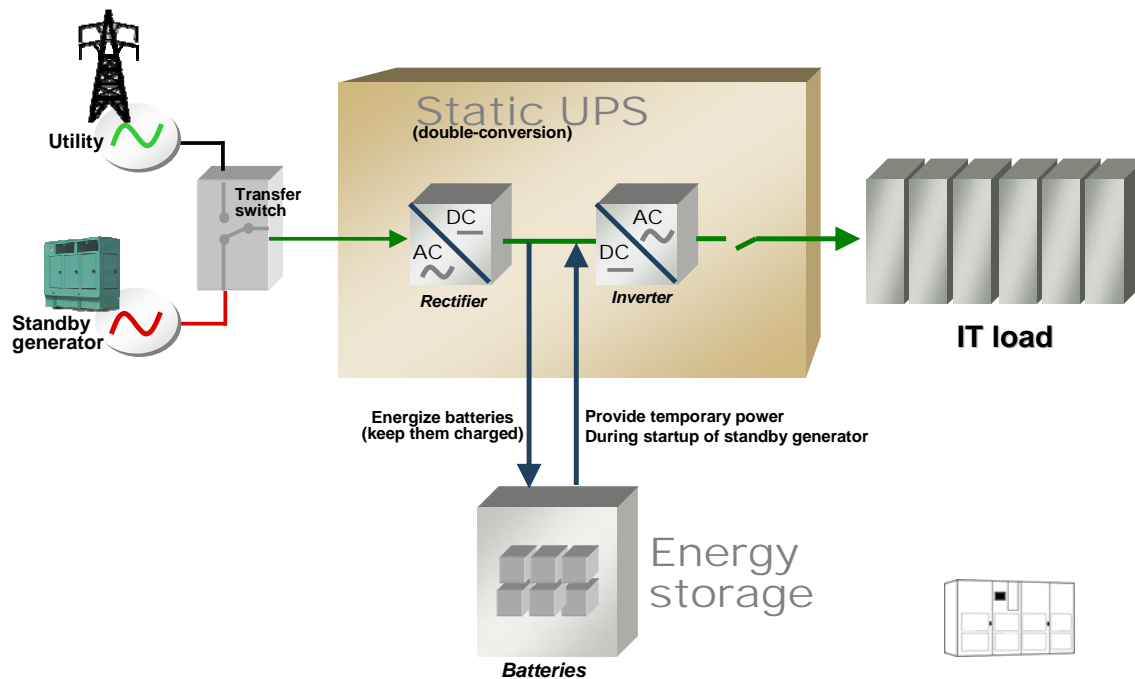

If the generator(s) fails to come online, the UPS is configured with enough battery runtime and technological intelligence to allow for an orderly shutdown of the load. Not all static UPSs are internally configured as depicted in **Figure 2**. For more information on the various static UPS topologies (including double conversion and delta conversion), see APC White Paper #1, “[The Different Types of UPS Systems](#)”.

Rotary UPS

Rotary technology has been utilized for many years and came into prominence at a time when loads would commonly exhibit a low power factor (which resulted in increased losses in the power distribution system and thus, an increased energy cost) and high harmonics (which prematurely shortened the life of transformers and capacitors). Users would experience the dimming of lights, brought on by voltage dips and sags, when large motors turned on, for example. These load characteristics, in turn, would destabilize the electronics of connected loads within the electrical network.

To address these issues, synchronous condensers / line conditioners were introduced. These were the precursors of today's modern rotary UPSs. Over time these synchronous condensers began to incorporate motor generators, inverters and rectifiers. Batteries and / or flywheels were then added as an energy storage source and the modern rotary UPS was born.

Figure 3 – Static UPS using flywheel for energy storage

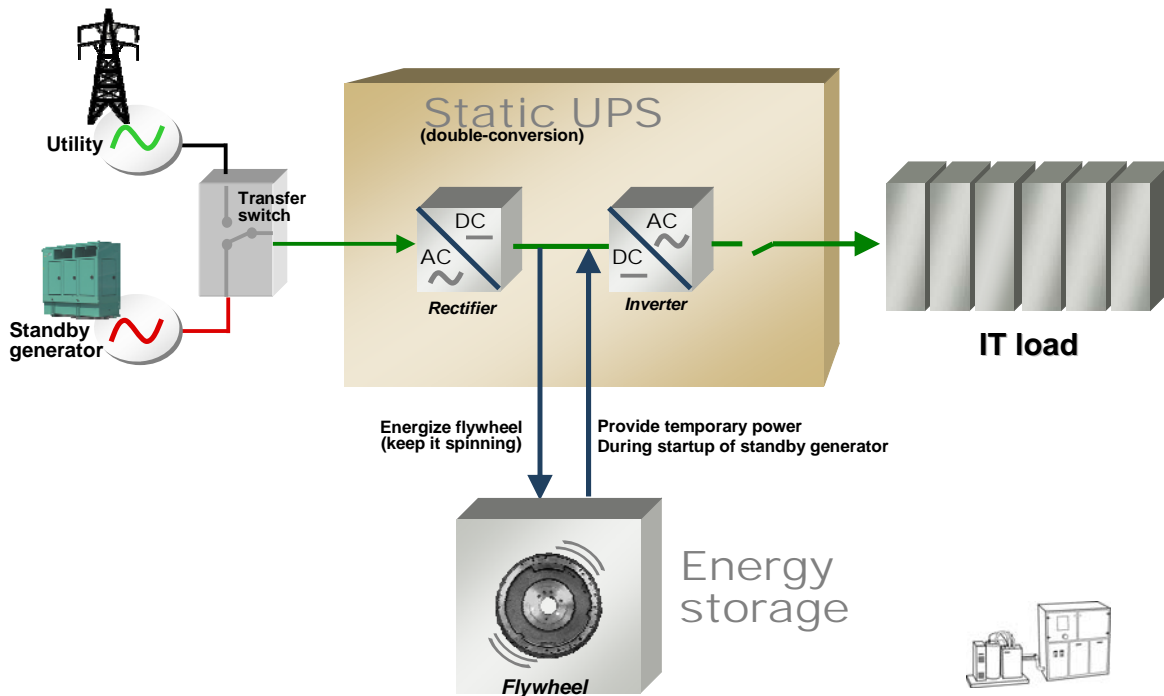

The nature of the data center load has evolved over the last three decades. For several years now, electronic equipment placed in data centers has been designed with power factor correction. In addition, static UPSs began to demonstrate dramatic improvement in both efficiency and filtering capabilities. Insulated gate bipolar transistors (IGBTs) were designed into static UPSs and have resulted in a supply of clean output sine wave to the loads. Ironically, the original reasons that rotary UPSs came into being as a viable solution (low power factor corrected loads, high harmonics) no longer exist in most modern data center environments.

The rotary UPS is called “rotary” because rotating components (such as a motor-generator) within the UPS are used to transfer power to the load. The true definition of a rotary UPS is any UPS whose output sine wave is the result of rotating generation. Therefore, the UPS in **Figure 3**, although it utilizes a flywheel as a rotating temporary energy storage source in case the utility fails, is not, by definition, a rotary UPS. According to Frost and Sullivan, flywheel UPSs represent less than three percent of the total UPS market¹ with the vast majority of installed UPSs utilizing batteries as their primary means of energy storage.

Types of Rotary UPS

Motor-generator / battery rotary UPS

When the utility power quality (voltage and frequency) falls within an acceptable range, then the motor component of the rotary UPS is driven directly from the utility. That motor then provides mechanical power to the generator component of the motor-generator (see **Figure 4**) to support the critical load with clean power. Also, the rectifier / inverter unit operates in stand-by mode during the time the utility is stable. That is, the rectifier is in “battery float” mode (the batteries get charged).

When utility voltage and frequency parameters fall outside of preset limits, then the rectifier / inverter unit begins to provide controlled power to the motor which is coupled directly to the generator to support the critical load. When a blackout occurs, the battery bank provides necessary power via the inverter to the motor-generator to support the load. The stored energy within the batteries provides sufficient ride-through to sustain the load until the standby generator (outside of the UPS) comes up to full operating speed.

Figure 4 – Motor-generator / battery rotary UPS

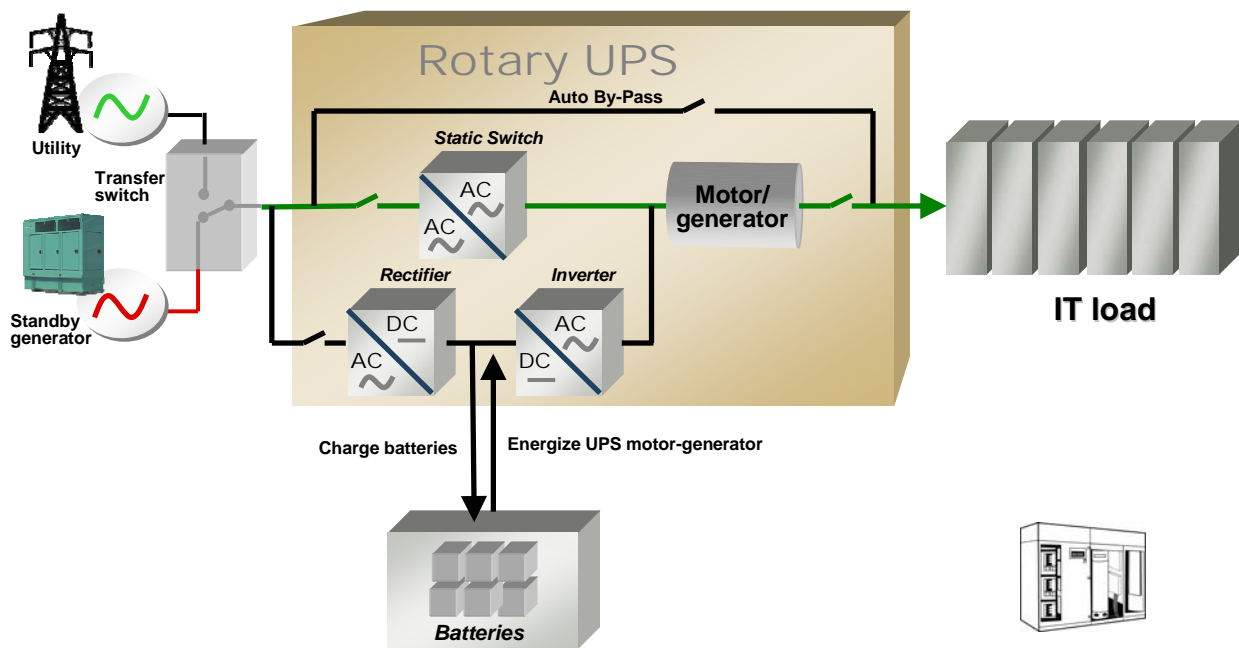

¹ Frost & Sullivan, *World Flywheel UPS Markets F308-27*, August 2005, page 1-1

Engine-coupled rotary UPS

The key components of an engine-coupled rotary UPS include the following: a motor-generator, a choke, a flywheel, a mechanical clutch, and a diesel engine. Under normal operation, the utility feeds power to the critical load via the filter (made up of the choke and motor). The same motor also provides the necessary power to the flywheel to retain kinetic storage of energy in case of emergency.

During failure mode, power is supplied by the flywheel to the motor-generator unit, which in turn supports the critical load for a few seconds before the diesel engine runs up to full speed. The clutch is then engaged to provide mechanical power to the motor-generator to supply continuity of power to the load (see **Figure 5**).

Figure 5 – Engine-coupled rotary UPS

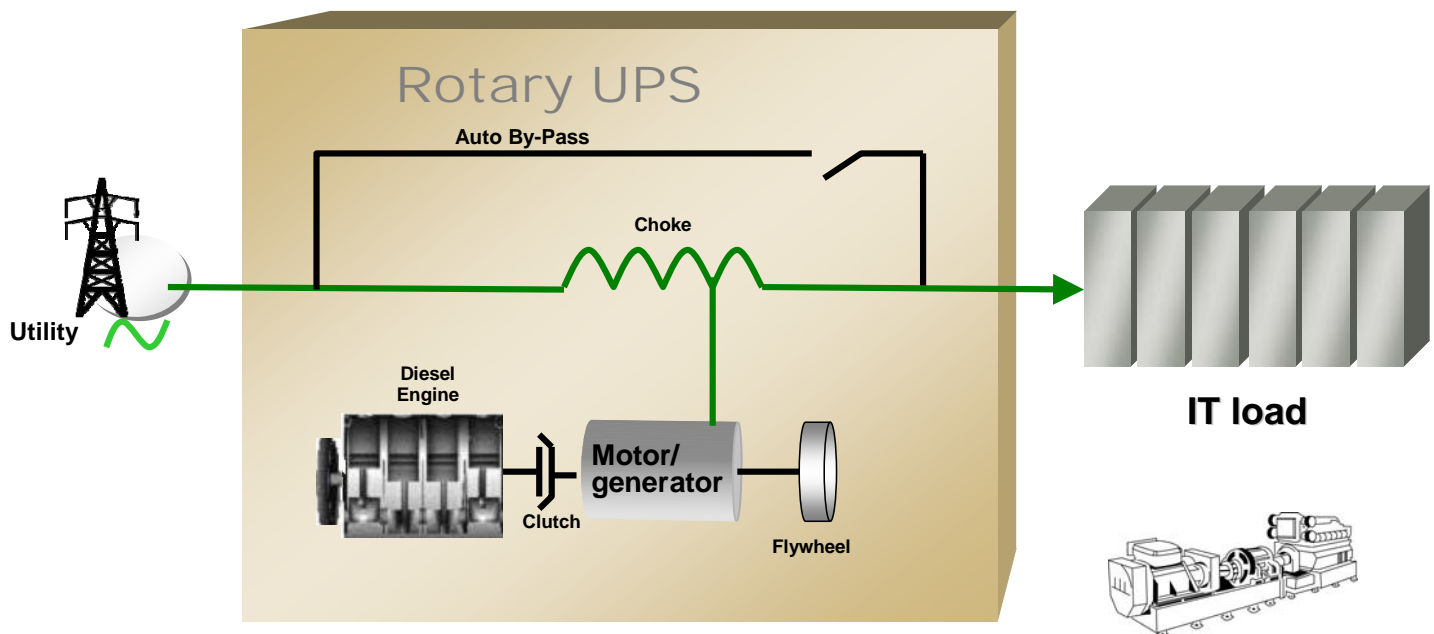

Practical Application to the Data Center Environment

Rotary UPSs, compared to static UPSs, represent a niche in the worldwide UPS market. According to IMS Research, only 4.3% of projected worldwide UPS revenues in 2008 will be rotary UPSs. The remaining 95.7% of the market consists of static UPS. The main consumer of rotary UPS equipment at this time is projected to be EMEA (7.4% of UPS revenues, 2008) with the Americas (4% of UPS revenues) and Asia (1.7% of revenues) trailing behind.²

In data centers, the rotary UPS also represents a niche within the installed base. The static UPS predominates, especially at power levels of 500 kW and below. Data center UPSs that fall into the power

² IMS Research, *The World Market for Uninterruptible Power Supplies*, September 2007, page 66

ranges of 20 kW to 200 kW are almost exclusively static. In the 200 kW to 500 kW range, rotary UPSs and flywheel UPSs begin to appear in niche applications (e.g. military and industrial). For mega data centers (over 100,000 square feet or 30,480 square meters) where 500 kW to multiple megawatt UPSs are required, both static and rotary UPSs are present.

Rotary UPSs are more suited to environments characterized by multiple short inrushes of power. One such example would be an environment where multiple motors are constantly turning on and off. Satellite stations and broadcast stations where high power amplifiers turn on and off in rapid and random sequence are other good examples of environments where rotary UPSs would be effective. Some rotary UPSs are also utilized for high security installations (e.g. military applications whose goal it is to prevent electrical eavesdropping) as a cost effective substitute for tempest filters.

Figure 6 – “Look and feel” comparison: static and rotary UPS

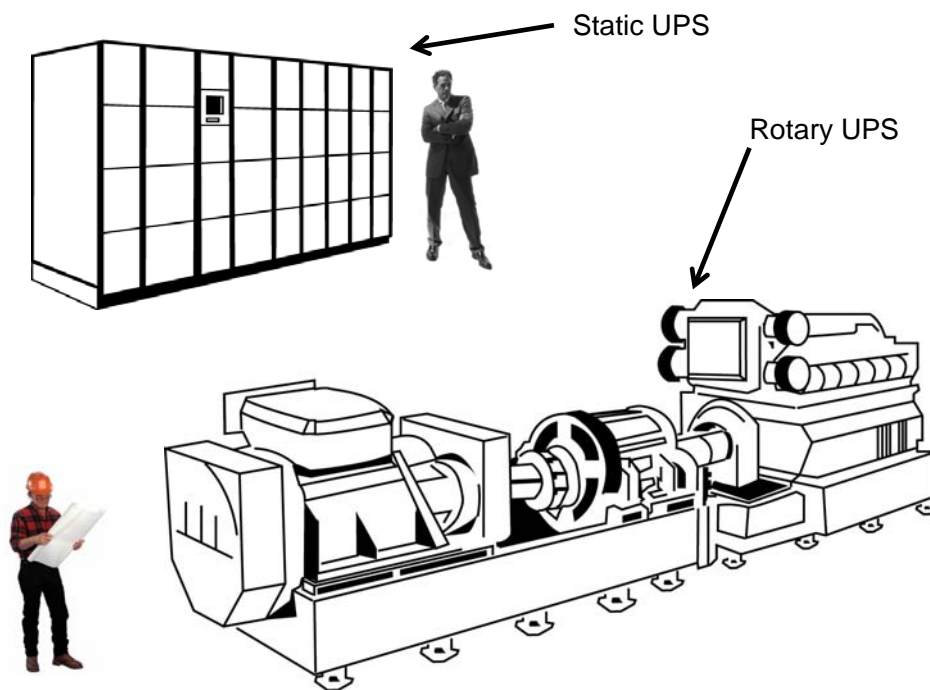

Characteristics of Rotary and Static UPS

Although static and rotary UPSs perform the same ultimate function (filtering utility power and providing power to the load in the event of a power disturbance), differences exist in the way static and rotary UPS are financed, installed, and operated.

Investment – Rotary UPSs represent a fixed investment. These UPSs are typically not modular. The up-front purchase needs to be oversized to incorporate possible future growth of the load. In fact, when

compared with a similar static unit, the rotary UPS solution can represent a 40% larger up front investment. Static UPSs are a more flexible investment. UPS modules can be added in smaller increments as the load demands grow.

The cost of associated auxiliary equipment is also different. At a minimum, a manual bypass switch is required to disengage the UPS from the input power and load during maintenance and repair. These switches are integrated into a static UPS but are standalone items with rotary UPSs and require additional cabling and support hardware. Facilities modifications also need to be considered. For static UPS, a separate battery room may have to be built (unless VRLA batteries are utilized instead of vented / flooded lead-acid batteries).

Figure 7–Comparison of mechanical and electronic equipment failure profiles

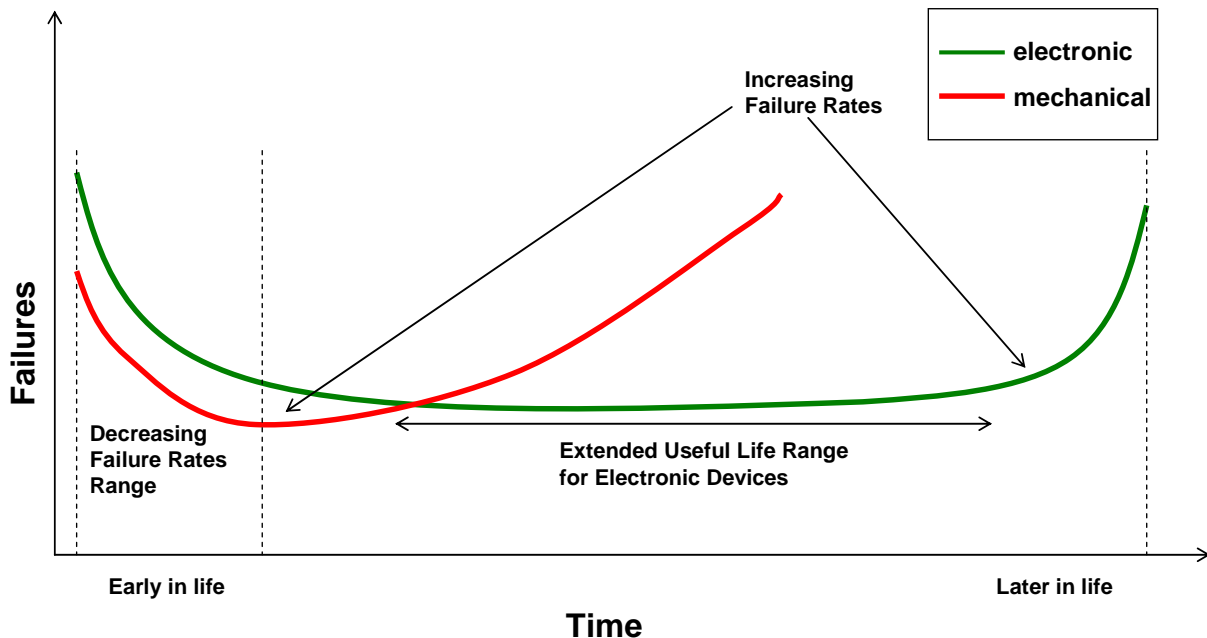

Rotary units may require additional or special ventilation equipment to purge fumes from working areas. Diesel rotary UPS may require the construction of a separate building to house the unit. In a cold climate, the rotary UPS will require thermostatically controlled lubricating oil, coolant heaters, or radiator louvers. Static UPSs also have the flexibility of residing within the data center white space (located in racks with servers) or grey space (located in the back room with electrical panels and similar infrastructure equipment). The larger rotary UPSs are most often placed outside or in a custom built room or building.

Maintenance – For a given level of availability, mechanical equipment requires more maintenance than electronic equipment. Maintenance schedules for mechanical devices such as rotary UPS include weekly (e.g., winding and bearing temperatures, diesel engine starter battery, diesel cooling water for pre heating), monthly (e.g., wear on carbon brushes, test system by switching over to emergency operation), yearly (e.g., after bridging with by-pass circuit, take UPS out of operation, clean UPS, change oil in clutch, check

operation of frequency control circuit) and 5 year inspections (replace bearings, inspect free wheel clutch). Static UPSs usually require one maintenance visit per year (depending on environmental conditions).

The curves in **Figure 7** illustrate failure rates for both electronic equipment (such as a static UPS) and mechanical equipment (such as a rotary UPS). By comparing both curves, it is evident that electronic equipment is characterized by a more extended useful life range. Mechanical equipment, with moving parts is, by its very nature, characterized by more parts replacement. In addition, the reliability of a mechanical device is directly correlated to the frequency of its maintenance (see **Figure 8**). Thus, the TCO of a rotary UPS will increase only if a high level of availability is maintained.

Figure 8 – Mechanical device frequency of maintenance to outages ratios

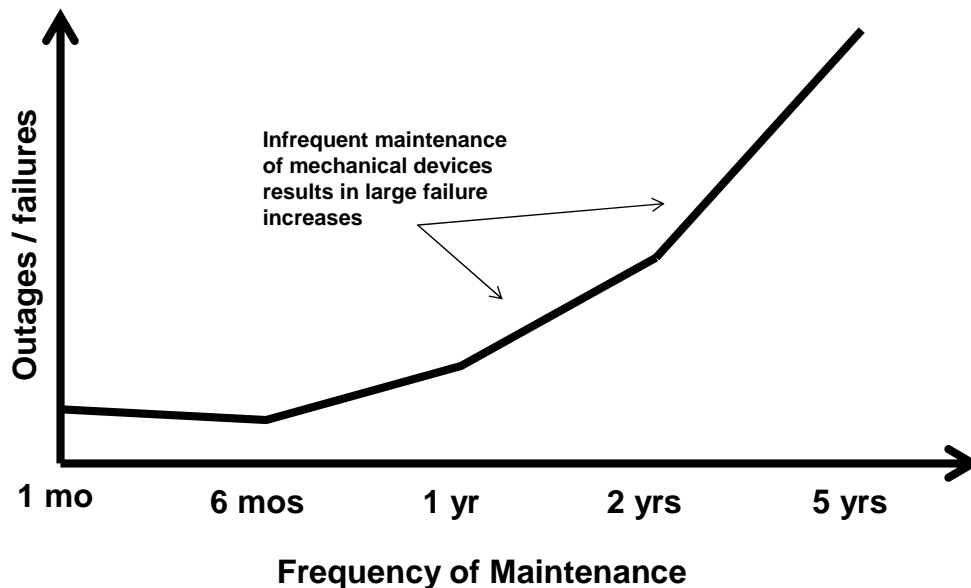

Static UPSs also require investments in maintenance. In addition to the occasional replacement of cards and circuit boards, the batteries that support the static UPS must be maintained. IEEE standards for batteries include recommendations for regular inspections (monthly, quarterly or yearly), periodic cleaning, adjustment and testing, monitoring and detailed analysis and record keeping. Flooded or vented lead acid batteries require a significant amount of monitoring and maintenance. Valve regulated lead acid (VRLA) batteries, which are encased in cartridges, and which are by far the most common batteries utilized by static UPSs, require much less maintenance.

Environmental impact – Static UPS systems are installed inside of a building (and often inside of a data center) while a significant percentage of rotary UPSs are installed outside of the building or within a specially built enclosure. Rotary UPSs tend to be noisier as a diesel generator is activated whenever a deviation outside of 59.9 or 60.12 Hz (Americas) and 49.9 or 50.1 Hz (EMEA) is experienced. This is because rotary UPS often rely on flywheels as their source of energy storage. A string of batteries can provide five to 15

minutes or more of backup power, while a flywheel can typically supply only 8 to 10 seconds of backup. Therefore in a rotary / flywheel set up, utilization of a standby generator will more often come into play. A greater reliance on the diesel generator could present an environmental issue, because many communities have emissions regulations that limit how many hours per month a diesel generator can run.

In a power-bridging capacity, both flywheels and batteries support the load until the generator starts. However, with the longer runtime of batteries, it is possible to program the generator to start only when an outage exceeds a specific duration.

Flywheel systems, in most cases, do not have this luxury, and the generator must start for every outage no matter how short. This is a disadvantage because, once the generator starts, it has to run for a minimum period of time no matter how long (or short) the utility outage is. Running a generator is something to be avoided whenever possible (except as required for monthly maintenance), because of noise and exhaust emissions issues.

In addition, over time, the diesel engine component of a lightly loaded rotary UPS will build up carbon deposits within the exhaust chamber. As a result, the crankshaft will deliver reduced kW output when high demand is suddenly imposed on the engine.

Table 2 – UPS component MTBF sample data

UPS Component	Sample MTBF (hours)
Rectifier / charger	100,000
Battery	120,000
Inverter	70,000
Static Switch (normal light usage)	475,000

Reliability – Both static and rotary UPSs are quite reliable. Two measures are generally considered, MTBF (mean time between failures) and MTTR (mean time to repair). The *higher* the MTBF number, the better (e.g. a device that breaks down after 20,000 hours of operation is more reliable than one that breaks down after 10,000 hours of operation). The *lower* the MTTR, the better (a device that takes an average of 4 hours to repair is preferable to a similar device that takes 8 hours to repair). **Table 2** illustrates a list of key UPS components with examples of typical MTBF figures.

Failures rarely occur within the UPS but do occur more often other related elements of the overall power train. Both static and rotary UPS are often reliant on diesel generators to support the load for more extended periods of time. However, because of the shorter energy storage run time of associated flywheels (or use of the closely coupled diesel engine), the rotary UPS goes to diesel more often. The risk with

reliance on diesel generators is that, according to IEEE standard 493, diesel generators have a failure rate of one for every 74 start attempts. In addition to the issue of generator starts, it is also important to calculate the time it takes the rotary UPS to reach nominal torque (the time it takes to bring the diesel engine up to a speed capable of delivering the necessary shaft horsepower to the motor-generator). In many cases, more than 15 seconds are required to fully secure the power generation.

Generators can fail for multiple reasons. They rely on one fuel tank. The fuel can be contaminated (e.g. water leaks into tank), the fuel supply can be exhausted (e.g. someone forget to refill tanks after testing), the fuel supply is starved (can't get fuel to the engine). The hot water heater that keeps the engine block warm can fail. If generators are located 5 feet apart, a fire can fail both. The input air louvers can fail to open. In addition, a transient overload of gensets is nearly certain if one of the generators fails to start.

Safety – Several safety precautions need to be taken into account when considering both rotary and static UPS. In the case of the static UPS, special attention needs to be given to the batteries associated with the UPS. If flooded or vented batteries are being utilized, users need to guard against hydrogen accumulation in the battery room. Large amounts of hydrogen, if not properly ventilated, can ignite and can significantly increase the risk of a fire.

Valve Regulated Lead-Acid (VRLA) or sealed battery cartridges, which are most often utilized with static UPSs, are much less of a concern when it comes to hydrogen leakage. In the case of a rotary UPS, noise pollution, toxic fumes from the diesel engine, fire hazard from the diesel fuel and proper encasement of the rotating motor / generator must all be considered.

Weight – Both rotary and static UPS floor units are quite heavy and may require strengthening of the floor to support their weight. Rotary UPSs are often placed on the ground floor basement areas because of their heavy weight. In these cases, the risk of flooding needs to be evaluated prior to installation.

Heat and airflow – Rotary unit produce more heat than static units as a result of the motor generator. Add on cooling devices have to be considered in order to maintain a proper temperature if the unit is placed indoors. If the UPS is operated under adverse conditions, availability will suffer. Specific precautions must be taken for dirty, hot, cold, or corrosive environments.

Although rotary UPSs can operate in a wider temperature range (5 to 40° C, or 41 to 104° F while operating, -20 to 80° C or -4 to 176° F when not operating), if batteries are utilized as a source of energy storage, a lower room temperature (approximately 20° C or 77° F is desirable). A rotary UPS used in a cold climate will most likely require thermostatically controlled lubricating oil, coolant heaters, and radiator louvers.

Service – Static UPS manufacturers have a much larger installed base of equipment and therefore have a robust service force in place that can provide comprehensive field support. As mentioned previously, the worldwide market share of rotary UPS is quite small and the number of rotary UPS service personnel reflects the size of the installed base.

In addition, maintenance of static UPS is somewhat simpler. Most static UPS components consist of standard blocks and cards with built-in diagnostics and are designed for rapid replacement. The kinetic energy storage device (the flywheel) in a diesel rotary UPS requires regular bearing replacement (Mean Time to Repair averages 24-36 hours). Therefore the site must plan for the inclusion of a suitable lifting device capable of handling weights ranging from 3 to 5 tons.

Architecture – Rotary UPSs lend themselves more to a centralized architecture approach whereas static UPSs have the flexibility to also deploy as distributed UPS solutions. A benefit of rotary is that all aspects of the power backup can be integrated into one solution (e.g. the diesel generator, the motor / generator, the clutch are all part of one unit). Although this may be attractive from a management perspective, it does present the potential for a single point of failure scenario (for example, if a fire were to occur in the one location where the rotary generator is located).

Figure 9– 3.5 MVA scalable to 10.5 MVA (1670 kVA rotary UPS blocks)

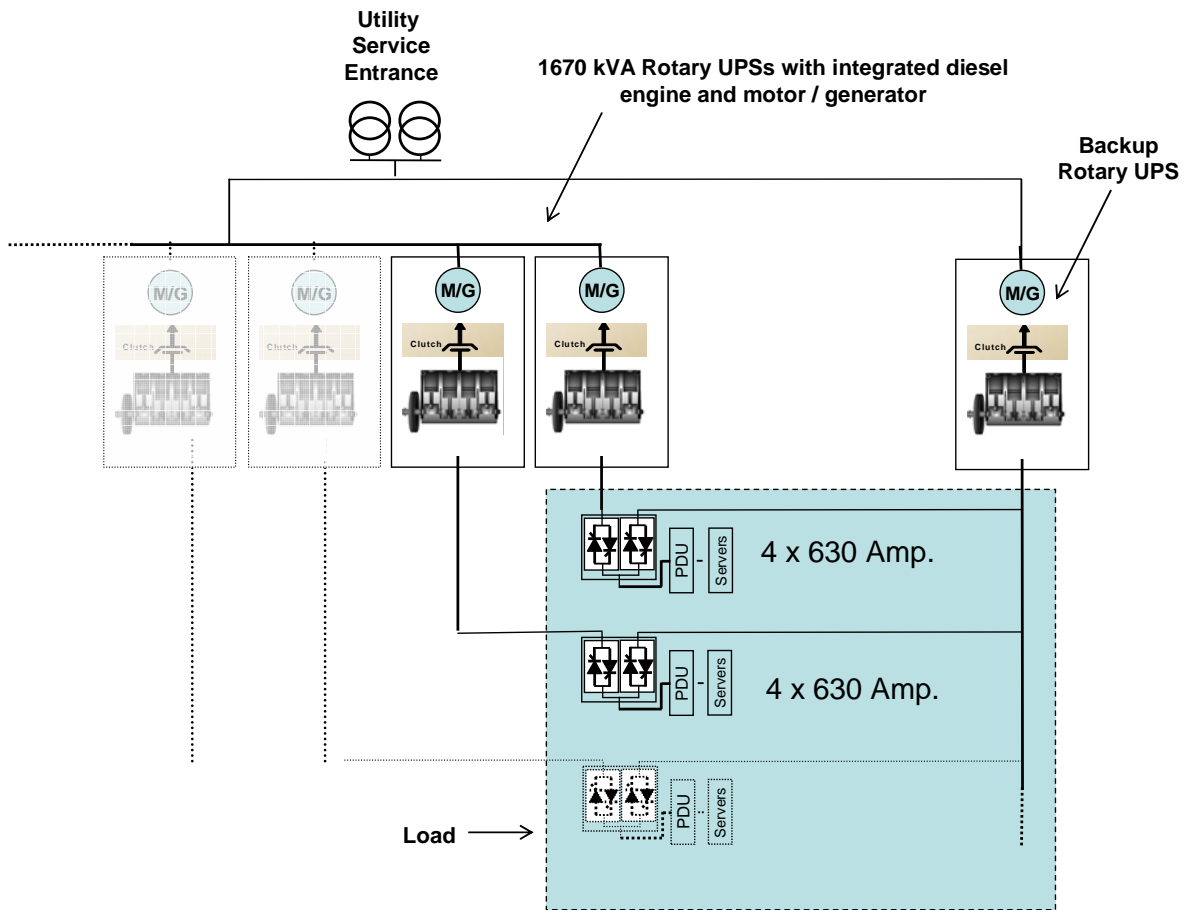

Figures 9 and 10 illustrate some fundamental differences between the way rotary UPSs and static UPSs are architected. The rotary implementation in Figure 9 illustrates that the power is distributed in bigger blocks. In this scenario, because the power is only available in bigger blocks, it becomes more difficult to target the UPS resource only to critical applications, or to optimize the UPS resource. Most data centers support multiple applications, some of which are considered much more critical than others.

The static UPS deployment in Figure 10 allows the data center owner to more efficiently target critical aspects of the load (thus avoiding the necessity of oversizing the UPSs up front) and demonstrates the increased flexibility the owner has to scale up when more critical applications are added. The scenario in Figure 10 also reduces the risk of a catastrophic failure because of the distributed nature of the modules.

Figure 10– 3.5 MVA scalable to 10.5 MVA (500 kVA static UPS modules)

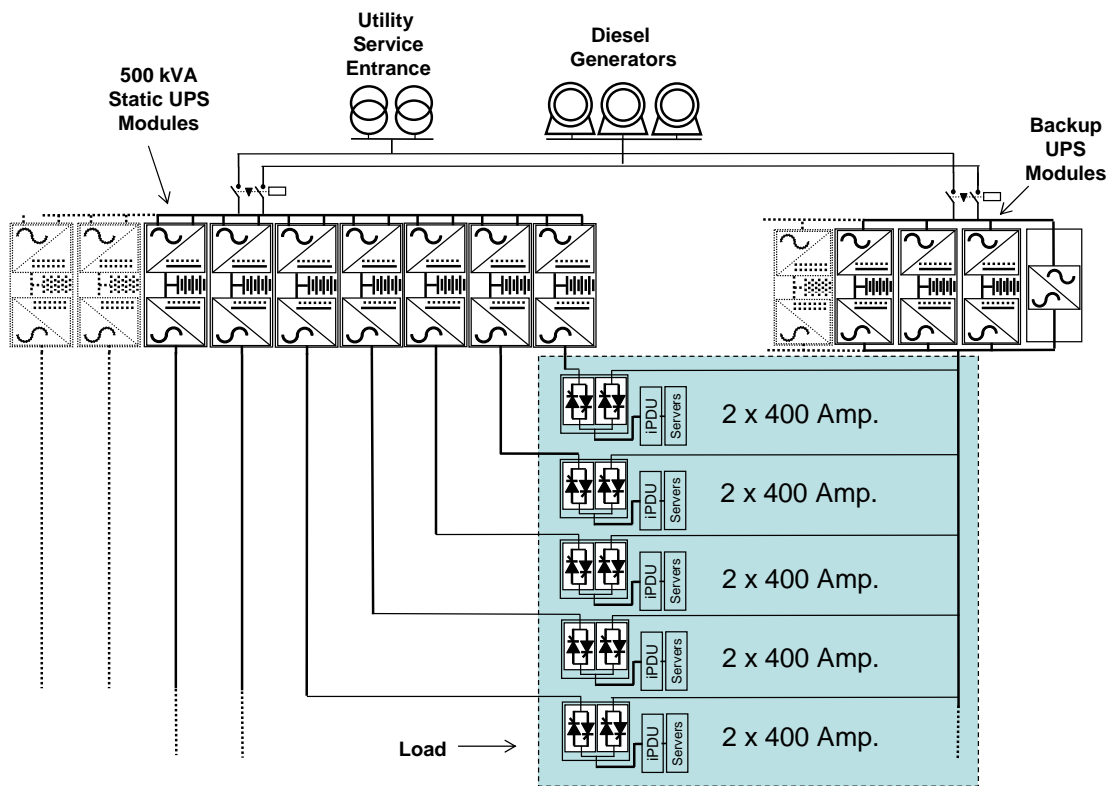

Conclusion

The range of applications for static UPSs is broad while the application ranges of rotary UPSs are more limited. In the domain of the data center, static UPSs represent the technology of choice. Rotary UPSs become more competitive in very large multiple megawatt data centers. The intent of this paper is to describe the major types of rotary UPSs and to contrast the technology with that of static UPSs. The differences in UPS design offer certain advantages and disadvantages depending upon the physical environment and electrical environment of the site.

About the Authors

Carl Cottuli is Vice President of the Data Center Science Center, a research organization within Schneider Electric's Critical Power and Cooling Division. He has responsibility for identifying data center physical infrastructure trends, communicating new ideas into the marketplace, and advising various product development groups on new data center requirements. Prior to joining the Data Center Science Center he managed APC's Global Service Organization. He has over twenty years experience in the electrical design and installation industry, has held senior management positions at Russell Electric, prior to joining APC, and holds a degree in Electronics Engineering.

Jean-Francois Christin is Business Development Manager for APC-MGE's Secure Power Solutions organization. His 17 years of experience in the power systems industry includes management of technical support in APC-MGE's South Asia and Pacific region, and management of technical communication and business development in the EMEA/LAM region. He is member of LPQI, actively participates in international power and energy conferences, and trains subject matter experts on topics related to power quality.